

Stop screw

AS 08/15

- Safely sets the mechanical end stop position



Stop screw for series F2 sensors

Dimensions

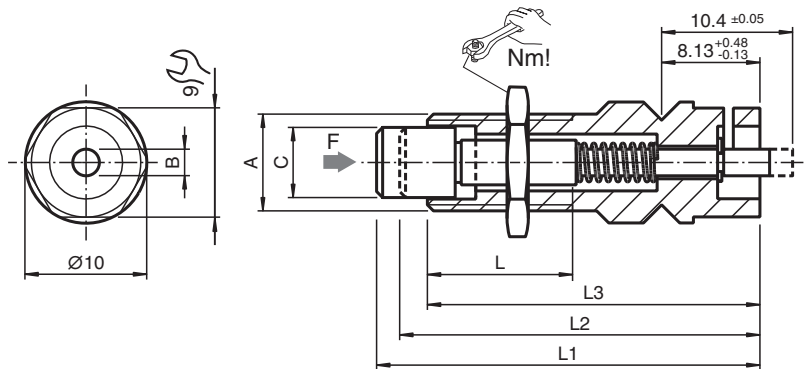

Technical Data

Mechanical specifications	
Operating force	min. 1.5 N max. 2000 N
Material	Steel 1.1191 / AISI 1045 (C45)
Dimensions	
A	M8 x 1
B	2.2 mm
C	5.8 mm
L	12 mm
L1	31.7 mm
L2	29.8 mm
L3	27.5 mm
Tightening torque	max. 8 Nm
General information	
Note	If necessary, properly secure the lock nut
Scope of delivery	Stop screw Counter nut

Release date: 2020-03-24 Date of issue: 2020-03-30 Filename: 189990_eng.pdf

Refer to "General Notes Relating to Pepperl+Fuchs Product Information".

Pepperl+Fuchs Group
www.pepperl-fuchs.com

USA: +1 330 486 0001
fa-info@us.pepperl-fuchs.com

Germany: +49 621 776 1111
fa-info@de.pepperl-fuchs.com

Singapore: +65 6779 9091
fa-info@sg.pepperl-fuchs.com

PF PEPPERL+FUCHS